

TS-RK Rebuild Kit for TS-2 and TS-2.2 Installation Procedures

Installation of New Main Shaft and Bearings

Use truing stand part reference chart for the following instructions.

- Loosen set screws or cap screws located on both main shaft adjusting collars #209-2. Collars should rotate freely on main shaft #211S. Uprights #201-2/200-2 should now move at top when pushed left or right. On older stands it may be necessary to remove collar set screw completely and lubricate hole to free collars from main shaft.
- Remove right side upright pivot bolt #225-2 and pull upright toward the right.
- Turn knob #213S/215S clockwise to disengage main shaft from left side threaded pivot bushing #204LS.
- Pull knob #213S/215S to right and remove main shaft and right side upright from stand. Remove old collars and spring.
- Remove both knob #213S/215S and knob locknut #212S from main shaft.
- Remove left side upright pivot bolt and remove left side upright from base.
- Remove old bushings #232-2 from both uprights and install four new bushings into uprights.
- Grease both threaded pivot bushings on left and right side uprights. Use care not to mix up bushing or arms. Left side bushing has left hand threads and has yellow plating. Right side bushing has right hand threads. Grease pivoting surface and outer faces of bushings.
- Reinstall left side upright and pivot bolt back into base. Tighten bolt fully.
- Grease threads of new main shaft #211S. Install main shaft through hole in right side upright and into bushing. NOTE: Main shaft has both left and right hand threads. Right hand threads go to right side upright and left hand threads go to left side upright. Right side of main shaft has more threads than left side.
- Thread knob locknut onto right side of main shaft until 8 threads are exposed (distance of 16mm.) Install knob #213S/215S and tighten against locknut.
- Guide main shaft through right side of base.
- The following parts will be installed on main shaft between short base uprights: bearing washer #1458-3, needle bearing #748-1, bearing washer #1458-3, main shaft adjusting collar #209-2, spring #229, main shaft adjusting collar #209-2, bearing washer #1458-3, needle bearing #748-1, bearing washer #1458-3. NOTE: It is necessary to compress the spring to install the left hand set of collar, washers, and bearing.
- Install right side upright into base. DO NOT attach right side pivot bolt at this time.
- Sight from left side of base to align threads of pivot bushing to threads of main shaft. Grab main shaft to raise or lower as necessary. Rotate threaded bushing as necessary to best align main shaft and bushing threads.
- Push left bushing against end of main shaft. Maintain pressure against main shaft and rotate knob counter-clockwise. If more than one rotation of knob is required to engage main shaft into bushings, unthread main shaft and start threading again.
- Continue to thread knob counter-clockwise until main shaft just begins to protrude out left side pivot bushing.
- Install right side upright and pivot bolt into base. Tighten bolt fully.
- Grab both uprights and move them side-to-side until they appear approximately symmetrical.

Installation of Split Nylon Bushings #235-2 onto Caliper Arm

- Loosen caliper adjusting knob #217S/216S until caliper arm #207-2 is nearly vertical in order to relax tension in spring #206-2/210.
- Unhook spring #206-2 from caliper arm.
- Remove right side caliper locknut #233-2, washer #234-2/#1458-3, and old bushing #235-2.
- Install new bushing #235-2.
- Reinstall washer and nut on right side and tighten.
- Remove left side caliper locknut and washer. Remove old bushing and install new bushing #235-2.
- Reinstall washer and nut on left side and tighten.
- Check adjustment of caliper arm. Locknuts should be as snug as possible but still allow the caliper arm to freely move up and down.
- Raise caliper arm again to vertical position and reinstall spring.

- Lower caliper to working height of rim and tighten caliper adjusting knob #217S/216S.

Centering Adjustment of the TS-2/TS-2.2 Truing Stand

- Sight down the front of the stand. The top edge of the caliper mounting plate must be parallel to the main shaft. If it isn't, place a large adjustable wrench across the plate and twist as necessary to bring it into alignment.
- Either the #1554-1 Centering Gauge or a dished wheel is needed to determine if the wheel is centered in the stand. If using a wheel, use a dishing tool, such as the Park Tool WAG-4 or WAG-5, to determine the accuracy of the wheel.
- Place the wheel or Centering Gauge in the stand and rotate the upright adjustment knob just until the uprights touch the locknuts on the hub. DO NOT FORCE UPRIGHTS INTO HUB LOCKNUTS BY OVERTIGHTENING KNOB.
- Measure the distance between the left edge of the rim or gauge and the left base upright, as well as the distance between the right edge of the rim or gauge and the right base upright. If the measurements are different, gently tap the uprights sideways until the measurements are equal on both sides. Tighten the cap screws in the shaft adjusting collars.
- Remove wheel and check side-to-side play of uprights. Shaft adjusting collars and bearings should be fully against base. There should be little or no play in uprights.
- Reinstall wheel. Readjust collars only if there is excessive play in uprights.
- Rotate the caliper arm adjusting knob to raise the calipers close to rim. Open or close the calipers as necessary using the caliper adjusting knob to check that the rim is centered between the two calipers. If the rim is not centered, loosen the caliper arm nut #233-2 on one end of the caliper arm pivot shaft and tighten the opposite nut an equal amount. This will shift the entire caliper arm assembly toward the side that was tightened. Continue until rim is centered between the calipers. For example, if there is a gap between rim/gauge at left side caliper, loosen left caliper nut #233-2 and tighten right side caliper nut. This moves the entire caliper arm mechanism to the right.
- Double check the caliper arm for free motion. Over tightening caliper shaft nuts will bind caliper arm.

NOTE: While the TS-2 and TS-2.2 are designed to provide automatic dishing of the wheel, imperfections in the shape or condition of the axle or locknuts can affect the dish reading, as the imperfection is magnified significantly by the distance from the hub to the rim, where the actual reading is taken. As a result, for precision work, a dishing tool such as the Park Tool WAG-4 or WAG-5 should be used to verify final adjustments.

Installing Caliper Springs #222-SR and #222-SL

NOTE: Test caliper springs by moving caliper outward and releasing. If spring is not fatigued, save replacement springs #222-SR and #222-SL for future use. Note that right side spring #222-SR coils counter-clockwise, and left side spring #222-SL coils clockwise.

- Use tape or other mark on right side caliper to distinguish it from left side.
- Loosen caliper adjusting knob #224S/223S until shaft is nearly removed from caliper arm.
- Remove left side caliper locknut #226-2, caliper spacer #228-2R and spring #222-SL.
- Remove right side caliper locknut #226-2, caliper spacer #228-2R and spring #222-SR.
- Install spacer #228-2R and spring #222-SR onto right side of caliper bracket. Engage spring into hole in caliper bracket.
- Install right side caliper onto caliper bolt by tilting spring top downward and manipulating spring end into caliper. Next manipulate caliper and spring over spacer and onto the stud. Install and tighten locknut. Use care not to pinch spring coils between spacer and caliper.
- Install left side spring, spacer and caliper using similar technique.
- Check adjustment of caliper locknuts. Snug locknuts but do not over tighten. Pull back slightly on each caliper and release. If arm does not freely return, locknut is overly tight.
- Tighten caliper adjusting knob #224S/223S until caliper opens up to working position.
- Double check centering of TS-2/TS-2.2 and adjust as necessary using Centering Adjustments of the TS-2/TS-2.2 described above.

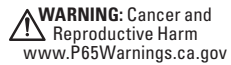

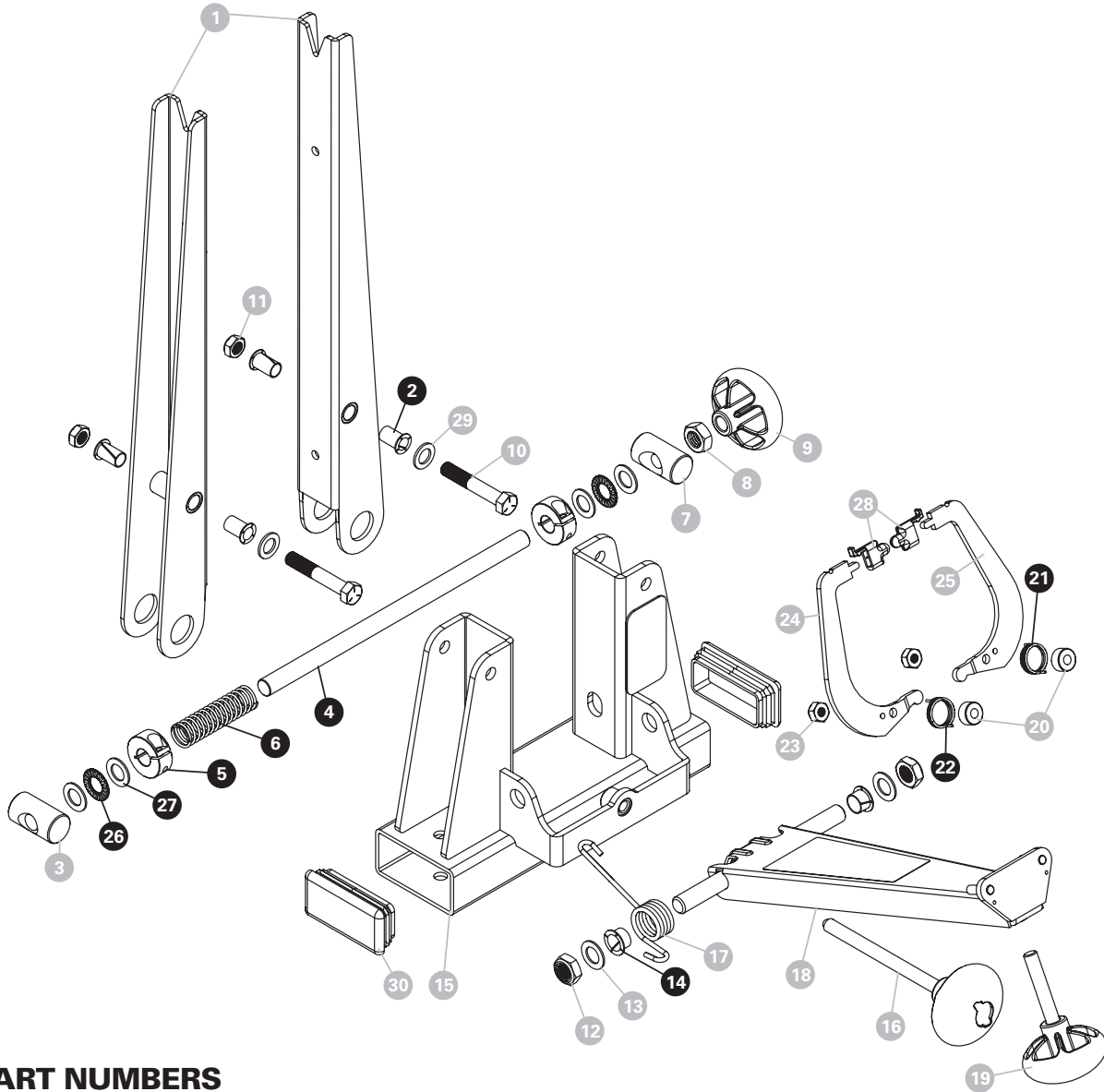

TS-RK PART NUMBERS

Ref. #	Part # TS-2/TS-2.2	Description	Qty.
1	201-2/200-2	Upright	
2	232-2	Split Nylon Bushing	4
3	204LS	Left Pivot Bushing	
4	211S	Main Shaft	1
5	209-2/209	Shaft Adjusting Collar w/ Cap Screw	2
6	229	Spring	1
7	204RS	Right Pivot Bushing	
8	212S	Locknut, 1/2 - 13	
9	215S	Upright Knob	
10	225-2	Bolt, 3/8 - 24 x 2-1/4"	
11	230-2	Thin Nylon Locknut, 3/8 - 24	
12	233-2	Thin Nylon Locknut, 1/2 - 20	
13	749-1	Bearing Washer, 1/2"	
14	235-2	Split Nylon Bushing	2
15	214-2/214-2.2	Base	
16	216S	Caliper Arm Knob	

Ref. #	Part # TS-2/TS-2.2	Description	Qty.
17	206-2/210	Spring	
18	207-2/207-2.2	Caliper Arm	
19	223S	Caliper Knob	
20	228-2R	Caliper Spacer Spring	
21	222SR	Right Spring	1
22	222SL	Left Spring	1
23	480-6	Thin Nylon Locknut, 1/4-20	
24	219-2L/237L	Left Caliper	
25	219-2R/236R	Right Caliper	
26	748-1	Needle Bearing	2
27	1458-3	Washer, 1/2"	4
28	238-2	Caliper Cap	
29	128-3	Flat Washer, 7/16" (TS-2.2P ONLY)	
30	227-2	Base End Cap (TS-2.2 ONLY)	

NOTE: Only item numbers in black included in TS-RK repair kit.